



### Features

- Simplex LC Connector, Bi-directional
- Single 3.3V Supply
- 10km Minimum Reach
- Commercial Temperature Available
- 1330nm DFB Laser transmitter, 1270nm receiver
- Compliant with IEEE 802.3-2005 10GBASE-LR and 10GBASE-LW
- SFP+ MSA SFF-8431 Compliant
- Digital Diagnostic SFF-8472 Compliant
- Telcordia GR-468 Compliant
- Color Coded Bail Latch Tube: Green
- RoHS Compliant

### Regulatory Compliance

Table 1 – Regulatory Compliance

Feature	Standard	Performance
Electrostatic Discharge (ESD) to the Electrical Pins	MIL-STD-883E Method 3015.7	Class 1 (>1000 V)
Electrostatic Discharge (ESD) at the Faceplate	IEC 61000-4-2	Compatible with Standards
Electromagnetic Interference (EMI)	FCC Part 15 Class B EN55022 Class B (CISPR 22B) VCCI Class B	Compatible with Standards
Laser Eye Safety	FDA 21CFR 1040.10 and 1040.11 EN60950, EN (IEC) 60825-1,2	Compatible with Class 1 Laser Product
RoHS Compliance	2002/95/EC	Compatible with Standards

## Absolute Maximum Ratings

**Table 2 – Absolute Maximum Ratings**

Parameter	Symbol	Min.	Typical	Max.	Unit	Notes
Storage Temperature	$T_s$	-40	-	+85	°C	
Supply Voltage	Vcc	-0.5	-	4.0	V	
Operating Relative Humidity	RH	-	-	85	%	

## Recommended Operating Conditions

**Table 3 – Recommended Operating Conditions**

Parameter	Symbol	Min.	Typical	Max.	Unit	Notes
Supply Voltage	Vcc	3.14	3.3	3.46	V	
Supply Current	Icc	-	-	300	mA	
Maximum Power Dissipation	Pvcc	-	-	1	W	
Inrush Current	$I_{IN-RUSH}$	-	-	30	mA	1
Power Supply Noise Rejection	PSR	66/99	-	-	mVp-p	2
Operating Temperature (Case)	$T_{opr}$	-5	-	70	°C	
Data Rate	DR	9.953	-	11.09	Gb/s	3

Note 1: Max. duration 500ms

Note 2: 66 mVp-p:10Hz-1MHz, 2% p-p, 3.3V power supply. 99 mVp-p: 1-10MHz, 3% p-p, 3.3V power supply.

Note 3: Supports 10GE at 9.953, 10.3125 and 11.09 Gb/s, 10GFC at 10.51 Gb/s. PRBS2<sup>31</sup>-1.

## Optical and Electrical Characteristics

**Table 4 – Transmitter Specifications (Optical)**

Parameter	Symbol	Min.	Typical	Max.	Unit	Notes
Optical Power	$P_{op}$	-8.2	-	0.5	dBm	
Optical Crosstalk	XT	-	-	-30	dB	
Average Launch Power Tx_Off	$P_{off}$	-	-	-30	dBm	
Extinction Ratio	ER	3.5	-	-	dB	
Eye Mask		Compliant with IEEE 802.3				
Mean Wavelength	$\lambda$	1320	1330	1340	nm	
Side Mode Suppress Ratio	SMSR	30	-	-	dB	
RIN <sub>12</sub> OMA	RIN	-	-	-128	dB/Hz	
Optical Modulation Amplitude	OMA	-5.2	-	-	dBm	
Launch Power in OMA minus TDP	OMA-TDP	-6.2	-	-	dBm	
Transmitter and Dispersion Penalty	TDP	-	-	3.2	dB	
Optical Return Loss Tolerance	-	-	-	12	dB	
Transmitter Reflectance	-	-	-	-12	dB	

**Table 5 – Receiver Specifications (Optical)**

Parameter	Symbol	Min.	Typical	Max.	Unit	Notes
Average Receiver Power	-	-14.4	-	0.5	dBm	4
Receiver Sensitivity in OMA	-	-	-	0.055(-12.6)	mW(dBm)	5
Stressed Receiver Sensitivity in OMA	-	-	-	0.093(-10.3)	mW(dBm)	
Wavelength	$\lambda$	1260	-	1280	nm	
Damage Threshold For Receiver	$P_{in, damage}$	-	-	4	dBm	
Receiver Total Jitter	TJ	-	-	0.70	UI	
Receiver Deterministic Jitter	DJ	-	-	0.42	UI	
Vertical Eye Closure Penalty	-	2.2	-	-	dBm	
Receiver Reflectance	RX_r	-	-	-12	dB	
LOS Assert	-	-30	-	-	dBm	
LOS De-Assert	-	-	-	-14.4	dBm	
LOS Hysteresis	-	0.5	-	-	dB	

Note 4: Average Receiver Power (Min) is informative and not the principal indicator of signal strength. A received power below this value cannot be compliant.

Note 5: Measured with a PRBS231-1 test pattern @10.3125Gbps, BER  $\leq$  10<sup>-12</sup>

**Table 6 – Electrical Specifications and Timing**

Parameter	Symbol	Min.	Typical	Max.	Unit	Notes
Input Differential Impedance	$R_{in}$	90	100	110	$\Omega$	
PECL Differential Data Input Swing	$V_{in, p-p}$	400	-	1600	mV	
PECL Differential Data Output Swing	$V_{out, p-p}$	300	600	900	mV	
Output Differential Impedance	$R_{out}$	80	100	120	$\Omega$	
TX_Fault, RX_LOS	$V_{OL}$	0.0	-	0.4	V	
	$V_{OH}$	Host_Vcc -0.5	-	Host_Vcc +0.3	V	
TX_Disable	$V_{IL}$	-0.3	-	0.8	V	
	$V_{IH}$	2.0	-	VccT+0.3	V	
RS0, RS1	$V_{IL}$	-0.3	-	0.8		
	$V_{IH}$	2.0	-	VccT+0.3		
Tx Disable Negate Time	$t_{on}$	-	-	2	ms	
Tx Disable Assert Time	$t_{off}$	-	-	10	$\mu$ s	
Time to Initialize 2-Wire Interface	$t_{2w\_start\_up}$	-	-	300	ms	
Time to Initialize	$t_{start\_up}$	-	-	300	ms	
Tx Fault Assert Time	$t_{fault\_on}$	-	-	1	ms	
Tx Fault Reset	TX_Fault Reset	10	-	-	$\mu$ s	
RX_LOS Assert delay	$t_{loss\_on}$	-	-	100	$\mu$ s	
RX_LOS Negate delay	$t_{loss\_off}$	-	-	100	$\mu$ s	

## Diagnostics

**Table 7 – Diagnostics**

Parameter	Range	Accuracy	Unit	Calibration	Formula
Temperature	-5 to 70	$\pm 3$	$^{\circ}$ C	External	$T_c(C) = T_{slope} * T_{ad} (16 \text{ bit signed twos complement value}) + T_{offset}$
Voltage	0 to Vcc	0.1	V	External	$V(\text{Volts}) = V_{slope} * V_{ad} (16 \text{ bit unsigned integer}) + V_{offset}$
Bias Current	0 to 120	5	mA	External	$I(\text{mA}) = I_{slope} * I_{ad} (16 \text{ bit unsigned integer}) + I_{offset}$
Tx Power	-8.2 to 0.5	$\pm 3$	dBm	External	$Tx\_PWR(\mu W) = Tx\_PWR_{slope} * Tx\_PWR_{ad} (16 \text{ bit unsigned integer}) + Tx\_PWR_{offset}$
Rx Power	-14.4 to 0.5	$\pm 3$	dBm	External	$Rx\_PWR(\mu W) = A_0 + A_1 * x + A_2 * x^2 + A_3 * x^3 + A_4 * x^4$

**Table 8 – EEPROM Serial ID (A0h)**

Name of Field	Description of Field	Address	Hex	ASCII
Identifier	Type of transceiver	0	03	
Ext. Identifier	Extended identifier of type of transceiver	1	04	
Connector	Code for connector type	2	07	
Transceiver	Code for electronic compatibility or optical compatibility	3	20	
		4	00	
		5	00	
		6	00	
		7	00	
		8	00	
		9	00	
10	00			
Encoding	Code for high speed serial encoding algorithm (64B/66B)	11	06	
BR.Nominal	Nominal signalling rate, units of 100MBd.	12	67	
Rate Identifier	Type of rate select functionality	13	00	
Length (SMF,km)	Link length supported for single mode fiber, units of km	14	0A	
Length (SMF)	Link length supported for single mode fiber, units of 100 m	15	64	
Length (50µm)	Link length supported for 50 um OM2 fiber, units of 10 m	16	00	
Length (62.5µm)	Link length supported for 62.5 um OM1 fiber, units of 10 m	17	00	
Length (Copper)	Link length supported for copper, units of meters	18	00	
Length (OM3)	Link length supported for 50 um OM3 fiber, units of 10 m	19	00	
Vendor Name	SFP vendor name (ASCII)	20	53	S
		21	4F	O
		22	55	U
		23	52	R
		24	43	C
		25	45	E
		26	50	P
		27	48	H
		28	4F	O
		29	54	T
		30	4F	O
		31	4E	N
		32	49	I
		33	43	C
		34	53	S
35	20	[Space]		

**Table 8 – EEPROM Serial ID (A0h)**

Name of Field	Description of Field	Address	Hex	ASCII
Unallocated		36	00	
Vendor OUI	SFP vendor IEEE company ID for Source Photonics Inc.	37	00	
		38	1F	
		39	22	
Vendor PN	Part number in ASCII, e.g. SPPLORXEBCDFA	40	53	S
		41	50	P
		42	50	P
		43	4C	L
		44	4F	O
		45	52	R
		46	58	X
		47	45	E
		48	42	B
		49	58	X
		50	43	C
		51	44	D
		52	46	F
		53	41	A
54	20	[Space]		
55	20	[Space]		
Vendor Rev.	Revision level for part number provide by vendor (ASCII)	56	41	A
		57	20	[Space]
		58	20	[Space]
		59	20	[Space]
Wavelength	Laser wavelength, 1330nm	60	05	
		61	32	
Unallocated		62	00	
CC_BASE	Check code for Base ID Fields (addresses 0 to 62)	63	xx	
Options	Indicates which optional transceiver signals are implemented	64	00	
		65	1A	

**Table 8 – EEPROM Serial ID (A0h)**

Name of Field	Description of Field	Address	Hex	ASCII
BR, max	Upper bit rate margin, unit of %	66	00	
BR, min	Lower bit rate margin, unit of %	67	00	
Vendor SN	Serial number	68-83	xx	
Date Code	Vendor's manufacturing date code	84-91	xx	
Diagnostic Monitoring Type	Indicates which type of diagnostic monitoring is implemented in the transceiver	92	68	
Enhanced Options	Indicates which optional enhanced features are implemented in the transceiver	93	F0	
SFF-8472 Compliance	Indicates which revision of SFF-8472 the transceiver complies with	94	03	
CC_EXT	Check code for Extended ID Fields (addresses 64 to 94)	95	xx	
Vendor Specific	Vendor Specific EEPROM	96-127	xx	

**Table 9 – Pin Definitions**

Pin	Symbol	Name/Description
1	VeeT	Module Transmitter Ground
2	TX_FAULT	Module Transmitter Fault
3	TX_DISABLE	Transmitter Disable; Turns off transmitter laser output
4	SDL	2-Wire Serial Interface Data Line (MOD-DEF2)
5	SCL	2-Wire Serial Interface Clock (MOD-DEF1)
6	MOD_ABS	Module Absent, connected to VeeT or VeeR in the module
7	RS0	Rate Select 0 – Not in use
8	RX_LOS	Receiver Loss of Signal Indication (in FC designated as RX_LOS, in SONET designated as LOS, and in Ethernet designated as NOT Signal Detect)
9	RS1	Rate Select 1 – Not in use
10	VeeR	Module Receiver Ground
11	VeeR	Module Receiver Ground
12	RXD-	Receiver Inverted Data Output
13	RXD+	Receiver Non-Inverted Data Output
14	VeeR	Module Receiver Ground
15	VCCR	Module Receiver 3.3V Supply
16	VCCT	Module Transmitter 3.3V Supply
17	VeeT	Module Transmitter Ground
18	TXD+	Transmitter Non-Inverted Data Input
19	TXD-	Transmitter Inverted Data Input
20	VeeT	Module Transmitter Ground

**Note**

1. The module ground pins, VeeR and VeeT, shall be isolated from the module case.
2. This pin is an open collector/drain output pin and shall be pulled up with 4.7K-10K ohms to a Host\_Vcc on the host board
3. Shall be pulled up with 4.7K-10K ohms to VccT in the module
4. This pin is an open collector/drain input pin and shall be pulled up with 4.7K-10K ohms to VccT in the module.

**SFP+ Module PCB Pinout**

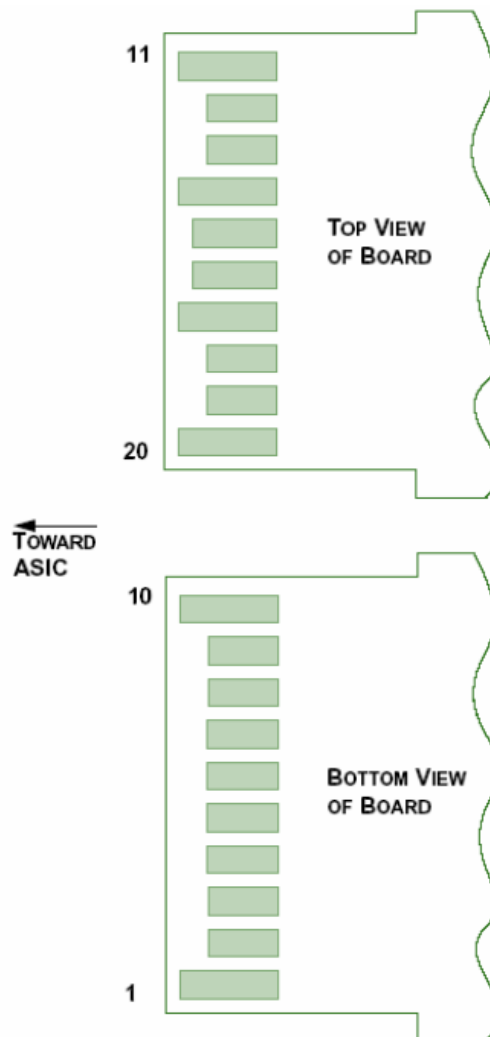

**Recommended Host Board Power Supply Circuit**

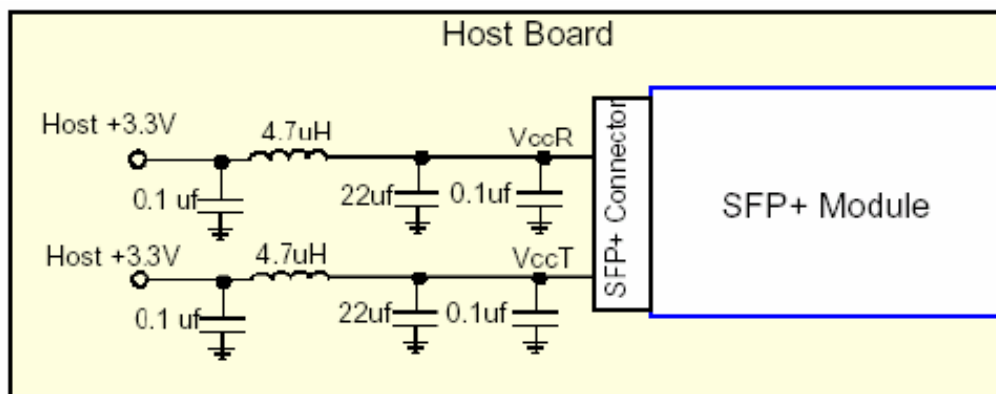

**Recommended Interface Circuit**

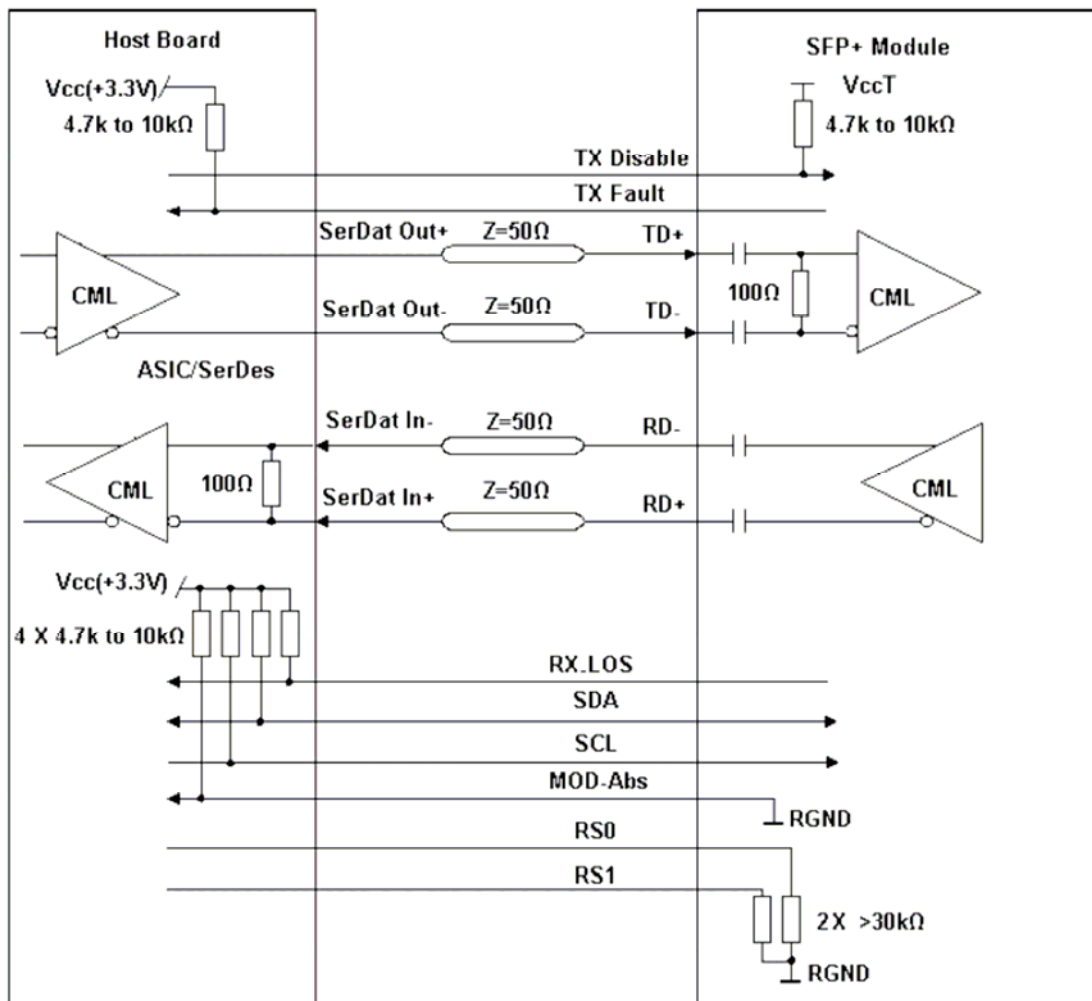

**Mechanical Diagram**

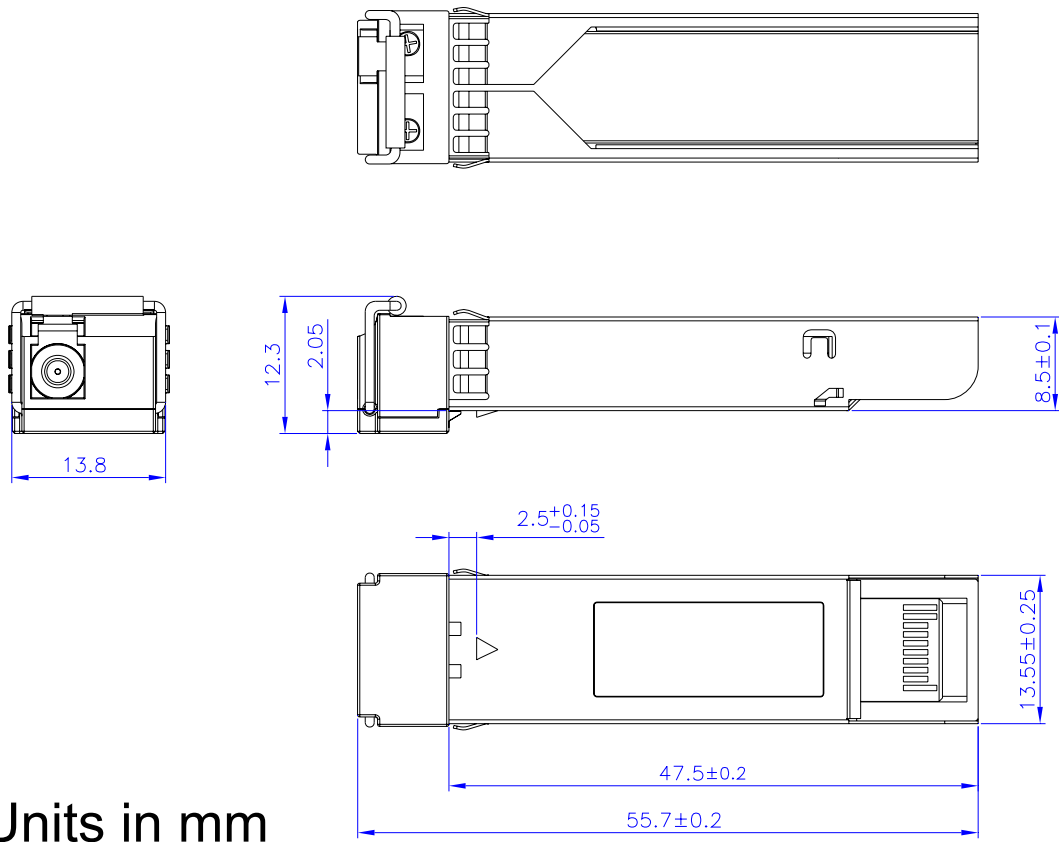

Units in mm

**Order Information**

**Table 10 – Order Information**

Part No.
SPPL-OR-XE-BX-CDFA

**Part Numbering Definition:**

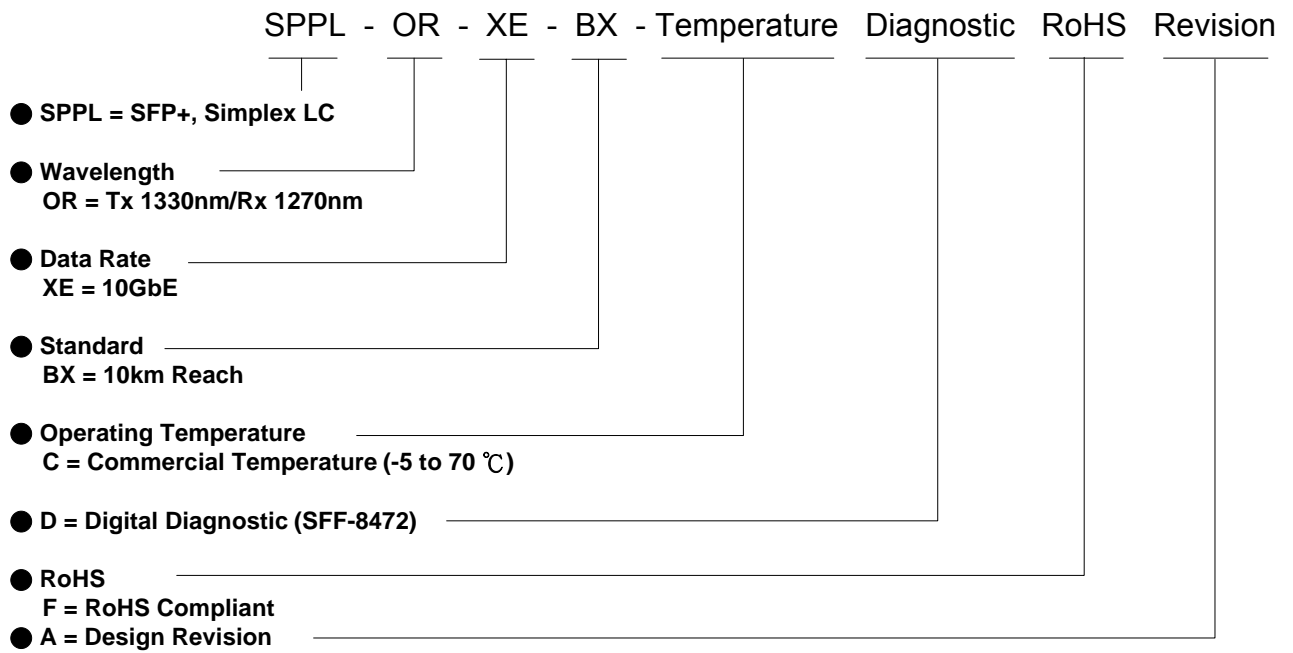

## Warnings

**Handling Precautions:** This device is susceptible to damage as a result of electrostatic discharge (ESD). A static free environment is highly recommended. Follow guidelines according to proper ESD procedures.

**Laser Safety:** Radiation emitted by laser devices can be dangerous to human eyes. Avoid eye exposure to direct or indirect radiation.

## Legal Notice

### IMPORTANT NOTICE!

All information contained in this document is subject to change without notice, at Source Photonics' sole and absolute discretion. Source Photonics warrants performance of its products to current specifications only in accordance with the company's standard one-year warranty; however, specifications designated as "preliminary" are given to describe components only, and Source Photonics expressly disclaims any and all warranties for said products, including express, implied, and statutory warranties, warranties of merchantability, fitness for a particular purpose, and non-infringement of proprietary rights. Please refer to the company's Terms and Conditions of Sale for further warranty information.

Source Photonics assumes no liability for applications assistance, customer product design, software performance, or infringement of patents, services, or intellectual property described herein. No license, either express or implied, is granted under any patent right, copyright, or intellectual property right, and Source Photonics makes no representations or warranties that the product(s) described herein are free from patent, copyright, or intellectual property rights. Products described in this document are NOT intended for use in implantation or other life support applications where malfunction may result in injury or death to persons. Source Photonics customers using or selling products for use in such applications do so at their own risk and agree to fully defend and indemnify Source Photonics for any damages resulting from such use or sale.

THE INFORMATION CONTAINED IN THIS DOCUMENT IS PROVIDED ON AN "AS IS" BASIS. Customer agrees that Source Photonics is not liable for any actual, consequential, exemplary, or other damages arising directly or indirectly from any use of the information contained in this document. Customer must contact Source Photonics to obtain the latest version of this publication to verify, before placing any order, that the information contained herein is current.

## Contact

### U.S.A. Headquarters

20550 Nordhoff Street  
Chatsworth, CA 91311  
USA

Tel: +1-818-773-9044

Fax: +1-818-773-0261

[sales@sourcephotonics.com](mailto:sales@sourcephotonics.com)

### China

Building #2&5, West Export Processing Zone  
No. 8 Kexin Road, Hi-Tech Zone  
Chengdu, 611731, China

Tel: +86-28-8795-8788

Fax: +86-28-8795-8789

[sales@sourcephotonics.com.cn](mailto:sales@sourcephotonics.com.cn)

### Taiwan

9F, No 81, Shui Lee Rd.  
Hsinchu, 300, Taiwan  
R.O.C.

Tel: +886-3-5169222

Fax: +886-3-5169213

[sales@sourcephotonics.com.tw](mailto:sales@sourcephotonics.com.tw)

© Copyright Source Photonics, Inc. 2007~2008

All rights reserved