



155M Bi-directional SFP Transceiver

(For 20km Point-point Transmission)



Members of Flexon™ Family

Description

SPS-35-03-EBX-INFH/SPS-53-03-EBX-INFH is high performance, cost effective transceiver. It is designed point-point FTTX applications at data rates of 155Mbps for 20km transmission.

SPS-35-03-EBX-INFH is normally used in the client (ONU), which transmits 1310nm and receives 1550nm optical signal; while SPS-53-03-EBX-INFH is used in the central office (OLT), which transmits 1550nm and receives 1310nm optical signal.

SPS-35-03-EBX-INFH and SPS-53-03-EBX-INFH features an EEPROM that contains the detailed product information stored for retrieval by host equipment. This information is accessed via the 2-wire serial CMOS EEPROM protocol. For further information, please refer to SFP Multi-Source Agreement (MSA).

SPS-35-03-EBX-INFH and SPS-53-03-EBX-INFH are compliant with RoHS.

Features

- ◆ 125~155Mbps data links
- ◆ 20km point-point transmission
- ◆ 1310nm FP Tx/1550nm PIN Rx for SPS-35-03-EBX-INFH
- ◆ 1550nm FP Tx/1310nm PIN Rx for SPS-53-03-EBX-INFH
- ◆ Class I laser product
- ◆ Low EMI and excellent ESD protection
- ◆ SFP MSA package with SC receptacle
- ◆ Operation case temperature:-40 to +85°C
- ◆ Detailed product information in EEPROM

Applications

- ◆ Point-to-Point FTTH Application
- ◆ Fast Ethernet

Standard

- ◆ Compatible with SFP MSA
- ◆ Compatible with IEEE 802.3ah
- ◆ Compliant with RoHS

Regulatory Compliance

The transceivers have been tested according to American and European product safety and electromagnetic compatibility regulations (See Table 1). For further information regarding regulatory certification, please refer to Source Photonics regulatory specification and safety guidelines, or contact with Source Photonics, Inc. America sales office listed at the end of documentation.

Table 1 - Regulatory Compliance

Feature	Standard	Performance
Electrostatic Discharge (ESD) to the Electrical Pins	MIL-STD-883E Method 3015.7	Class 1
Electrostatic Discharge (ESD) to SC Receptacle	IEC 61000-4-2	Compatible with standard
Electromagnetic Interference (EMI)	FCC Part 15 Class B	Compatible with standard
Laser Eye Safety	FDA 21CFR 1040.10 and 1040.11 EN (IEC) 60825-1,2	Compatible with Class 1 laser product.
RoHS	2002/95/EC 4.1&4.2 2005/747/EC	Compliant with standard RoHS

Absolute Maximum Ratings

Absolute Maximum Ratings are those values beyond which damage to the devices may occur.

Table 2– Absolute Maximum Ratings

Parameter	Symbol	Min.	Max.	Unit
Storage Temperature	T_s	-40	+85	°C
Supply Voltage	V_{CC}	-0.5	3.6	V
Operating Humidity	-	5	95	%

Recommended Operating Conditions

Table 3 - Recommended Operating Conditions

Parameter	Symbol	Min.	Typical	Max.	Unit
Operating Case Temperature	T_c	-40		+85	°C
Power Supply Voltage	V_{CC}	3.13	3.3	3.47	V
Power Supply Current	I_{CC}			300	mA
Data Rate			125/155		Mbps

Optical and Electrical Characteristics (SPS-35-03-EBX-INFH)

Table 4– Optical and Electrical Characteristics (TC=-40 to 85°C, V_{CC}=3.13 to 3.47V)

Parameter	Symbol	Min.	Typical	Max.	Unit	Notes
Transmitter						
Centre Wavelength	λ_C	1260		1360	nm	
Average Output Power	P_{out}	-14		-8	dBm	1
Spectral Width (RMS)	$\Delta\lambda$		2.5	7	nm	
Extinction Ration	ER	10			dB	
Output Optical Eye	ITU-T G.957 Compatible					2
Data Input Swing Differential	V_{IN}	500		2400	mV	3
Input Differential Impedance	Z_{IN}	90	100	110	Ω	
TX Disable	Disable	2.0		V _{CC} +0.3	V	
	Enable	0		0.8	V	
TX Fault	Fault	2.0		V _{CC} +0.3	V	
	Normal	0		0.8	V	
Receiver						
Centre Wavelength	λ_C	1480		1580	nm	
Receiver Sensitivity				-32	dBm	4
Receiver Overload		-8			dBm	4
Return Loss		14			dB	
LOS De-Assert	LOS_D			-34	dBm	
LOS Assert	LOS_A	-45			dBm	
LOS Hysteresis		0.5		4	dB	
Data Output Swing Differential	V_{OUT}	700		1200	mV	5
LOS	High	2.0		V _{CC} +0.3	V	
	Low	0		0.8	V	

Note:

1. The optical power is launched into SMF.
2. Measured with a PRBS 2²³-1 test pattern @155Mbps.
3. Internally AC coupled and terminated.
4. Measured with PRBS 2²³-1 test pattern@155Mbps, Extinction Ration ER=10dB, BER≤1×10⁻¹⁰.
5. Internally AC coupled.

Optical and Electrical Characteristics (SPS-53-03-EBX-INFH)

Table 5 –Optical and Electrical Characteristics (TC=-40 to 85°C, V_{CC}=3.13 to 3.47V)

Parameter	Symbol	Min.	Typical	Max.	Unit	Notes
Transmitter						
Centre Wavelength	λ_C	1480		1580	nm	

Average Output Power	P_{out}	-14		-8	dBm	1
Spectral Width (RMS)	$\Delta\lambda$		2.5	4.6	nm	
Extinction Ration	ER	10			dB	
Output Optical Eye	ITU-T G.957 Compatible					2
Data Input Swing Differential	V_{IN}	500		2400	mV	3
Input Differential Impedance	Z_{IN}	90	100	110	Ω	
TX Disable	Disable		2.0		Vcc+0.3	V
	Enable		0		0.8	V
TX Fault	Fault		2.0		Vcc+0.3	V
	Normal		0		0.8	V
Receiver						
Centre Wavelength	λ_C	1260		1360	nm	
Receiver Sensitivity				-32	dBm	4
Receiver Overload					dBm	4
Return Loss		14			dB	
LOS De-Assert	LOS_D			-34	dBm	
LOS Assert	LOS_A	-45			dBm	
LOS Hysteresis		0.5		4	dB	
Data Output Swing Differential	V_{OUT}	700		1200	mV	5
LOS	High		2.0		Vcc+0.3	V
	Low		0		0.8	V

Note:

1. The optical power is launched into SMF.
2. Measured with a PRBS $2^{23}-1$ test pattern @155Mbps.
3. Internally AC coupled and terminated.
4. Measured with PRBS $2^{23}-1$ test pattern@155Mbps, Extinction Ration ER=10dB, BER $\leq 1 \times 10^{-10}$.
5. Internally AC coupled.

EEPROM Information

The SFP MSA defines a 256-byte memory map in EEPROM describing the transceiver’s capabilities, standard interfaces, manufacturer, and other information, which is accessible over a 2 wire serial interface at the 8-bit address 1010000X (A0h). The memory contents refer to Table 6.

Table 6 - EEPROM Serial ID Memory Contents (A0h)

Addr.	Field Size (Bytes)	Name of Field	Hex	Description
0	1	Identifier	03	SFP
1	1	Ext. Identifier	04	MOD4
2	1	Connector	01	SC
3—10	8	Transceiver	00 xx 02 00 00 00 00 00	Transmitter Code xx:10 for SPS-35-03-EBX-INFH and 08 for

				SPS-53-03-EBX-INFH
11	1	Encoding	03	NRZ
12	1	BR, nominal	02	155Mbps
13	1	Reserved	00	
14	1	Length (9um)-km	14	20km
15	1	Length (9um)	C8	20km
16	1	Length (50um)	00	
17	1	Length (62.5um)	00	
18	1	Length (copper)	00	
19	1	Reserved	00	
20—35	16	Vendor name	53 4F 55 52 43 45 50 48 4F 54 4F 4E 49 43 53 20	“SOURCEPHOTONICS”(ASC II)
36	1	Reserved	00	
37—39	3	Vendor OUI	00 00 00	
40—55	16	Vendor PN	53 50 53 33 35(35 33) 30 33 45 42 58 49 4E 46 48 20 20	“SPS3503EBXINFH”or“SPS5303EBXINFH” (ASC II)
56—59	4	Vendor rev	31 30 20 20	ASC II (“31 30 20 20” means 1.0 revision)
60-61	2	Wavelength	05 1E/06 0E	1310nm/1550nm
62	1	Reserved	00	
63	1	CC BASE	xx	Check sum of bytes 0 - 62
64—65	2	Options	00 1A	TX_DISABLE, TX_FAULT, Loss of Signal
66	1	BR, max	00	
67	1	BR, min	00	
68—83	16	Vendor SN	xx xx xx xx xx xx xx xx xx xx xx xx xx xx xx xx	ASC II .
84—91	8	Vendor date code	xx xx xx xx xx xx 20 20	Year (2 bytes), Month (2 bytes), Day (2 bytes)
92—94	3	Reserved	00 00 00	
95	1	CC EXT	xx	Check sum of bytes 64 - 94
96—255	160	Vendor specific		

Note: The “xx” byte should be filled in according to practical case. For more information, please refer to the related document of SFF-8472 Rev 9.5.

Recommended Host Board Power Supply Circuit

Figure 1 shows the recommended host board power supply circuit.

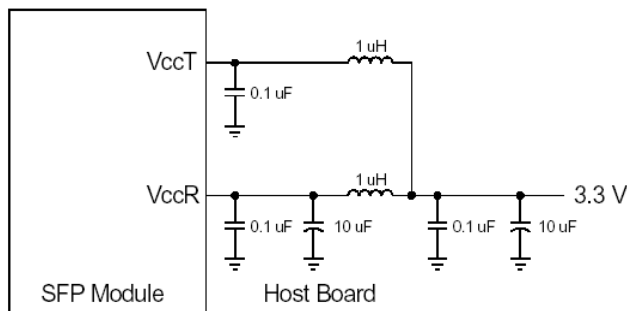

Figure 1, Recommended Host Board Power Supply Circuit

Recommended Interface Circuit

Figure 2 shows the recommended interface circuit.

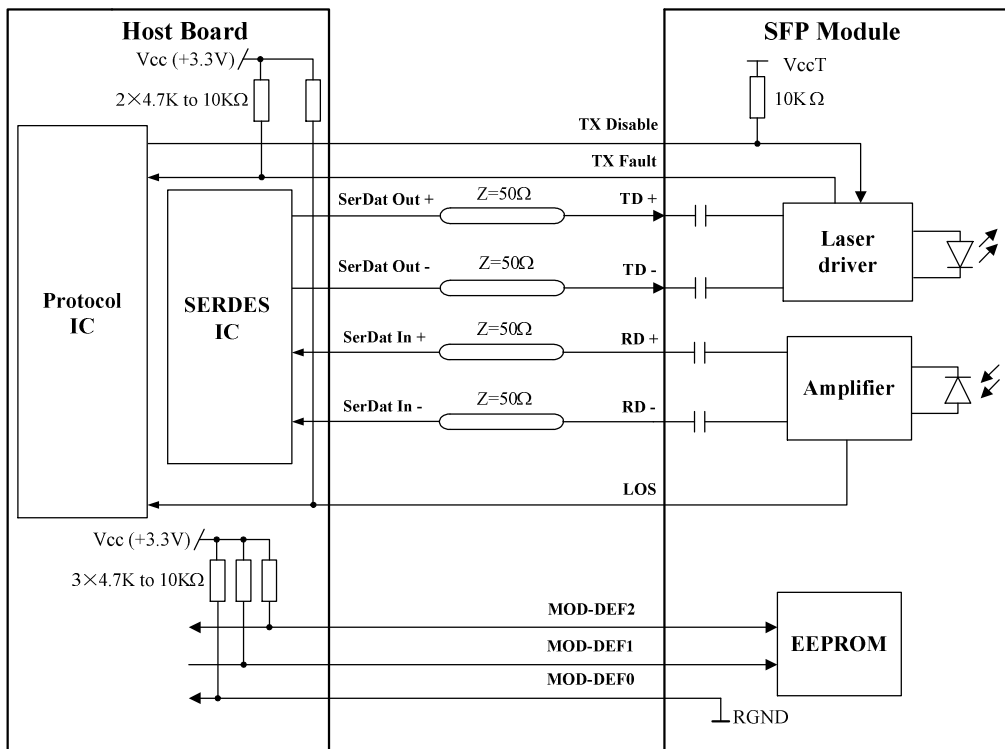

Figure 2, Recommended Interface Circuit

Pin Definitions

Figure 3 below shows the pin numbering of SFP electrical interface. The pin functions are described in Table 7 and the accompanying notes.

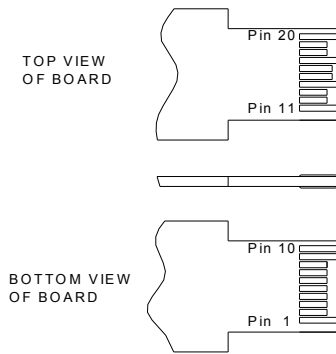

Figure 3, Pin View

Table 7– Pin Function Definitions

Pin No.	Name	Function	Plug Seq.	Notes
1	VeeT	Transmitter Ground	1	
2	TX Fault	Transmitter Fault Indication	3	Note 1
3	TX Disable	Transmitter Disable	3	Note 2
4	MOD-DEF2	Module Definition 2	3	Note 3
5	MOD-DEF1	Module Definition 1	3	Note 3
6	MOD-DEF0	Module Definition 0	3	Note 3
7	Rate Select	Not Connected	3	
8	LOS	Loss of Signal	3	Note 4
9	VeeR	Receiver Ground	1	
10	VeeR	Receiver Ground	1	
11	VeeR	Receiver Ground	1	
12	RD-	Inv. Received Data Out	3	Note 5
13	RD+	Received Data Out	3	Note 5
14	VeeR	Receiver Ground	1	
15	VccR	Receiver Power	2	
16	VccT	Transmitter Power	2	
17	VeeT	Transmitter Ground	1	
18	TD+	Transmit Data In	3	Note 6
19	TD-	Inv. Transmit Data In	3	Note 6
20	VeeT	Transmitter Ground	1	

Notes:

- TX Fault is an open collector output, which should be pulled up with a 4.7k~10kΩ resistor on the host board to a voltage between 2.0V and Vcc+0.3V. Logic 0 indicates normal operation; logic 1 indicates a laser fault of some kind. In the low state, the output will be pulled to less than 0.8V.
- TX Disable is an input that is used to shut down the transmitter optical output. It is pulled up within the module with a 4.7k~10kΩ resistor. Its states are:
 - Low (0~0.8V): Transmitter on
 - (>0.8V, <2.0V): Undefined
 - High (2.0~3.465V): Transmitter Disabled

Open: Transmitter Disabled

3. MOD-DEF 0,1,2 are the module definition pins. They should be pulled up with a 4.7k~10kΩ resistor on the host board. The pull-up voltage shall be VccT or VccR.
 MOD-DEF 0 is grounded by the module to indicate that the module is present
 MOD-DEF 1 is the clock line of two wire serial interface for serial ID
 MOD-DEF 2 is the data line of two wire serial interface for serial ID
4. LOS is an open collector output, which should be pulled up with a 4.7k~10kΩ resistor on the host board to a voltage between 2.0V and Vcc+0.3V. Logic 0 indicates normal operation; logic 1 indicates loss of signal. In the low state, the output will be pulled to less than 0.8V.
5. These are the differential receiver outputs. They are AC-coupled 100Ω differential lines which should be terminated with 100Ω (differential) at the user SERDES.

These are the differential transmitter inputs. They are AC-coupled, differential lines with 100Ω differential termination inside the module.

Mechanical Design Diagram

The mechanical design diagram is shown in Figure 4.

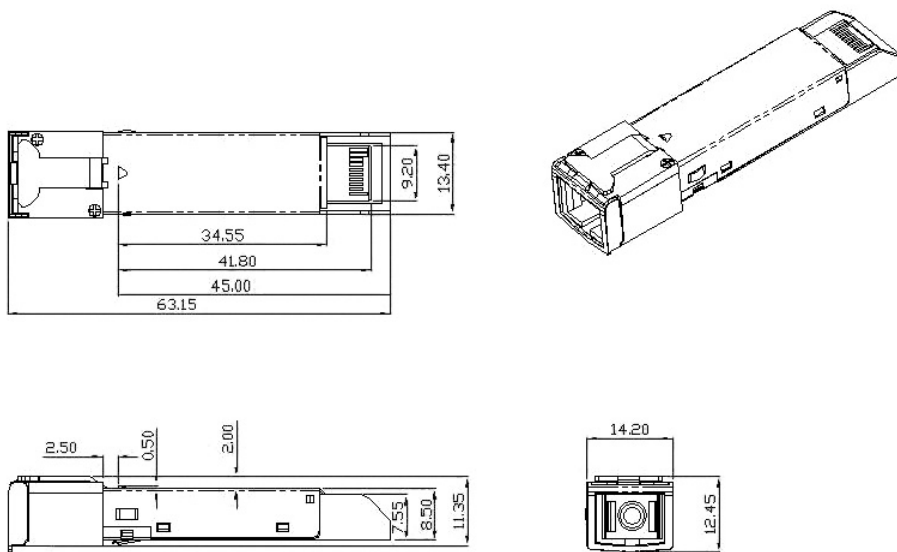
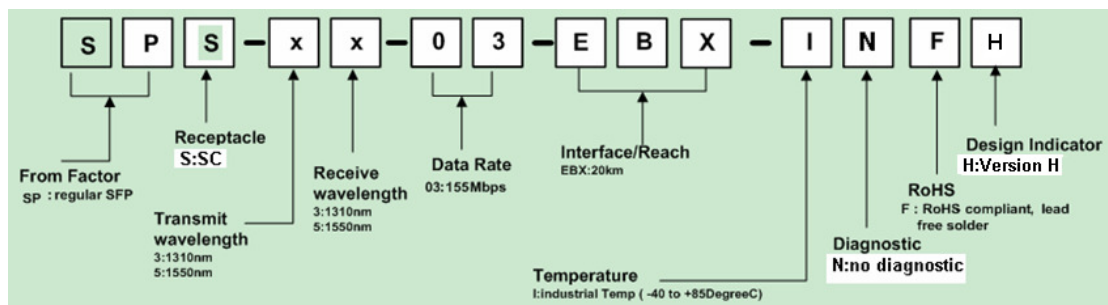

Figure 4, Product Mechanical Design Diagram

Ordering information



Part No.	Product Description
SPS-35-03-EBX-INFH	1310nm(TX)/1550nm(RX), 125~155Mbps, bi-directional SFP for ONU, Compliant with RoHS, -40 to 85 ^o C
SPS-53-03-EBX-INFH	1550nm(TX)/1310nm(RX), 125~155Mbps, bi-directional SFP for OLT, Compliant with RoHS,-40 to 85 ^o C

Related Documents

For further information, please refer to the following documents:

- ◆ *Flexon™ SFP Installation Guide*
- ◆ *Flexon™ SFP Application Notes*
- ◆ *SFP Multi-Source Agreement (MSA)*

Obtaining Document

You can visit our website:

<http://www.Sourcephotonics.com>

Or contact with Sourcephotonics, Inc. America Sales Office listed at the end of documentation to get the latest documents.

© Copyright Source Photonics Inc. 2008

All Rights Reserved.

All information contained in this document is subject to change without notice. The products described in this document are NOT intended for use in implantation or other life support applications where malfunction may result in injury or death to persons.

The information contained in this document does not affect or change Source Photonics product specifications or warranties. Nothing in this document shall operate as an express or implied license or indemnity under the intellectual property rights of Source Photonics or third parties. All information contained in this document was obtained in specific environments, and is presented as an illustration. The results obtained in other operating environment may vary.

THE INFORMATION CONTAINED IN THIS DOCUMENT IS PROVIDED ON AN "AS IS" BASIS. In no event will Source Photonics be liable for damages arising directly from any use of the information contained in this document.

Contact

U.S.A. Headquarter:
20550 Nordhoff Street
Chatsworth, CA91311
U. S. A.
Tel: 818.773.9044
Fax: 818.773.0261
M-S@sourcephotonics.com.cn